

# TB100

## PERFORMANCE CRITERIA FOR TB100 TURBO BLOWER

For correct operation of this unit, the following maximum conditions must not be exceeded :-

Speed (maximum)	36000rpm
Airflow	1380-6300m3/h
Pressure	300-1000mbar
Axial power	75kW
VDF Voltage	380 - 480V
VDF Frequency	50 - 60Hz

### CONTROL / INSTRUMENTATION

Type of Controller	PLC
Network to SCADA, MCP	Standard : MODBUS TCP/IP and MODBUS RTU Optional : PROFIBUS-DP and ETHERNET IP
Input	Analog : 4-20 mA or 0-10v / digital : Dry contact
Output	Analog : 4-20 mA or 0-10v / digital : Relay (2A)
Interface	7" Touchscreen
Total weight	546kg

$$\text{Pressure ratio} = \frac{\text{Absolute outlet pressure}}{\text{Absolute inlet pressure}}$$

Normal (sea level) ambient conditions are 1013 mbar & 15 deg C.

A BLOWER is a unit in which the inlet pressure is substantially equal to the ambient pressure.

## UNIQUE FEATURES

- \* Around 20% more energy efficient than PD blowers
- \* Noise levels are typically around 75-80dB(A)
- \* 100% lubricant free due to air foil bearings
- \* Compact size and light weight compared to PD blowers
- \* Low maintenance, no lubricants only filter change needed

## SPECIFICATION

**PMS motors:** Are optimised for high speed rotation, minimising current loss and delivering a maximum efficiency of 98%. No power loss due to direct drive. Stop-start test conducted over 100,000 times.

**Air Foil bearings:** Are 100% lubricant free, contactless and eco-friendly. Special coating reduces frictional wear providing long service life. No maintenance needed.

**Impeller:** Made from high strength heat treated aluminium. Manufactured with state-of-the-art aerodynamic technology. High precision 5-axis machining ensures wide flow range and surge margin. Anodised coating enhances surface strength.

**Cooling System:** Self-cooling system so no separate power source required. No maintenance required.

**Inverter:** Less than 1% starting current. 0.3% Unload Power Consumption. KEB (Kinetic Energy Back-up) function for enhanced safety in case of power failure.

.....  
All blowers are individually tested. Test certificates will be issued if requested.

A comprehensive Installation and Operating Instruction folder is supplied with every blower.

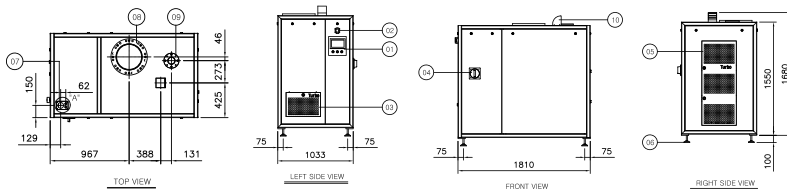
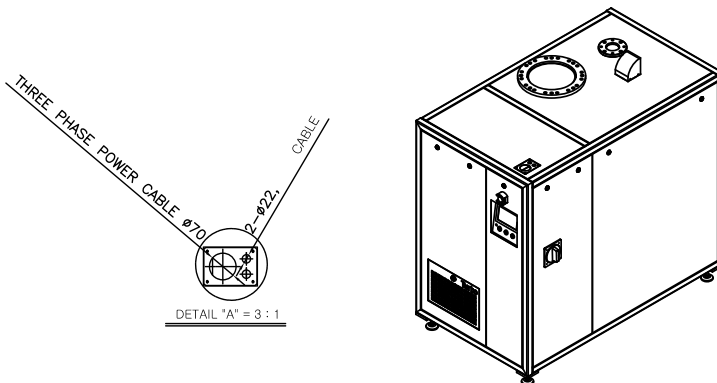

weight: 546kg

Dimensions in millimetres (inch conversions in brackets)