

RH SERIES

HEAVY DUTY ROTARY VALVES

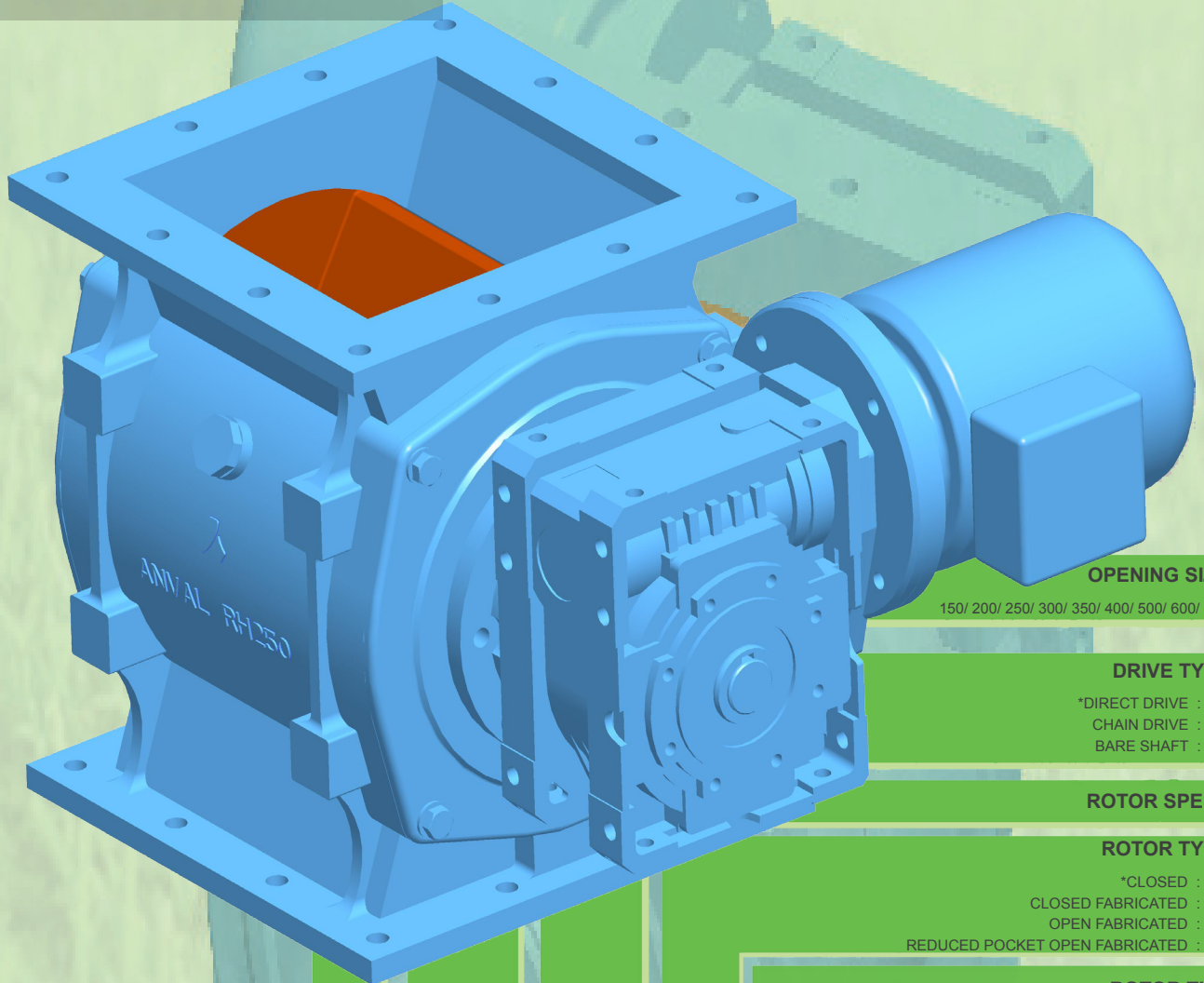

OPENING SIZE

150/ 200/ 250/ 300/ 350/ 400/ 500/ 600/ 750

DRIVE TYPE

*DIRECT DRIVE : D
CHAIN DRIVE : C
BARE SHAFT : B

ROTOR SPEED

ROTOR TYPE

*CLOSED : N
CLOSED FABRICATED : M
OPEN FABRICATED : Q
REDUCED POCKET OPEN FABRICATED : R

ROTOR TIPS

FLEXIBLE TIPS(N,M,Q,R) : F
WEAR TIPS(Q,R) : W

PURGE SEALING

GREASE PURGE : G
AIR PURGE* : A
* For temperature > 300 °C

TEMPERATURE RANGE

200 - 300 °C : X
300 - 400 °C : Y
> 400 °C : Z

PROXIMITY SENSOR : P

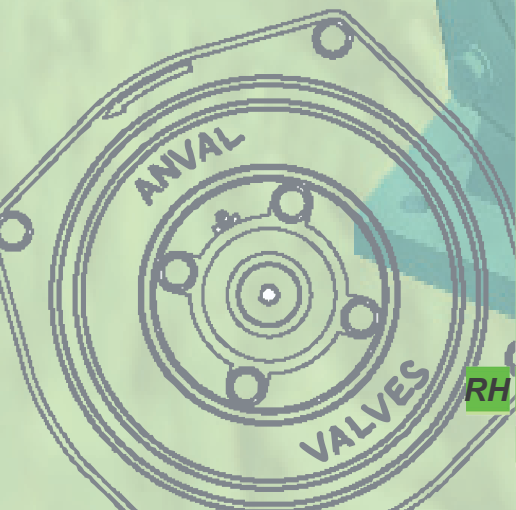

RH 300 D 14 M F G - -

BASIC DESIGNATION

EXTENDED DESIGNATION

*DEFAULT
*MANDATORY

DIRECT DRIVE (D) > DIMENSIONS

RH

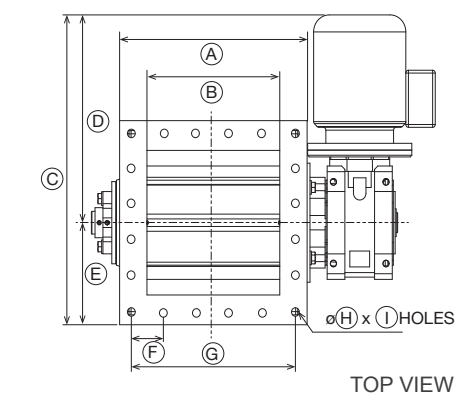

TOP VIEW

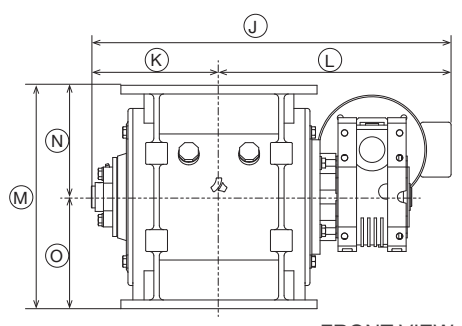

FRONT VIEW

NAME	RH 150	RH 200	RH 250	RH 300	RH 350	RH 400	RH 500	RH 600	RH 750
A	□ 240	□ 300	□ 360	□ 430	□ 480	□ 530	□ 630	□ 760	□ 930
B	□ 150	□ 200	□ 250	□ 300	□ 350	□ 400	□ 500	□ 600	□ 750
C#	440	517	563	598	678	894	1026	1068	1309
D#	320	367	383	383	438	629	711	940	1050
E	120	150	180	215	240	265	315	380	465
F	70	85	105	94	106	94	114	100	108
G	210	255	315	376	424	470	570	700	864
H	12	14	15	15	15	15	15	18	18
I	12	12	12	16	16	20	20	28	32
J#	507	574	660	718	800	932	1089	1182	1376
K	150	190	232	250	290	325	375	457	465
L#	357	384	428	468	510	607	714	725	911
M	240	330	410	470	525	620	760	900	1120
N	120	165	205	235	262.5	310	380	450	560
O	120	165	205	235	262.5	310	380	450	560
NET WEIGHT	50	84	146	183	255	400	650	1058	1750
GROSS WEIGHT	65	105	165	215	280	440	715	1120	1820

ALL DIMENSIONS IN MM, WEIGHT IN KGS.

APPROXIMATE DIMENSION ONLY. VARIES WITH MOTOR SIZE AND GEARBOX VARIATION.

BARE SHAFT (B) > DIMENSIONS

RH

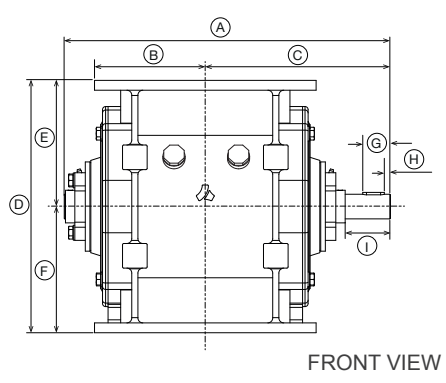

FRONT VIEW

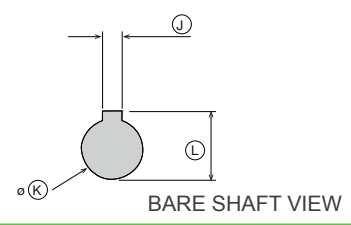

BARE SHAFT VIEW

NAME	RH 150	RH 200	RH 250	RH 300	RH 350	RH 400	RH 500	RH 600	RH 750
A	375	437	530	590	630	730	870	1025	1125
B	150	150	180	215	290	265	315	380	465
C	225	260	300	331	350	396	455	505	660
D	240	330	410	470	525	620	760	900	1120
E	120	165	205	235	262.5	310	380	450	560
F	120	165	205	235	262.5	310	380	450	560
G	30	35	45	45	65	50	50	75	50
H	5	5	10	10	5	5	10	10	5
I	60	60	75	75	72	77	51	55	75
J	8	8	12	12	14	14	18	18	20
K	25	30	40	40	45	50	60	60	70
L	28.3	33.3	43.3	43.3	48.3	53.3	63.3	63.3	74.9
NET WEIGHT	35	61	116	161	210	331	513	950	1500
GROSS WEIGHT	45	81	130	185	228	356	546	995	1560

ALL DIMENSIONS IN MM, WEIGHT IN KGS.

PROXIMITY SENSORS

RH

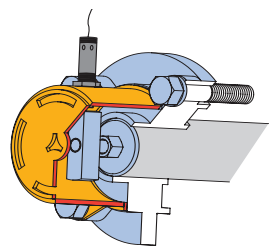

Underspeed sensors can be supplied and fitted to rotary valves. These are mounted on a specifically designed bracket that is bolted onto the bearing. The sensor fitted is 12mm in diameter with CD-PNP electrical connection and protection to IP67. The unit is suitable for temperatures from -25°C to +70°C.

CHAIN DRIVE (C) > DIMENSIONS

RH

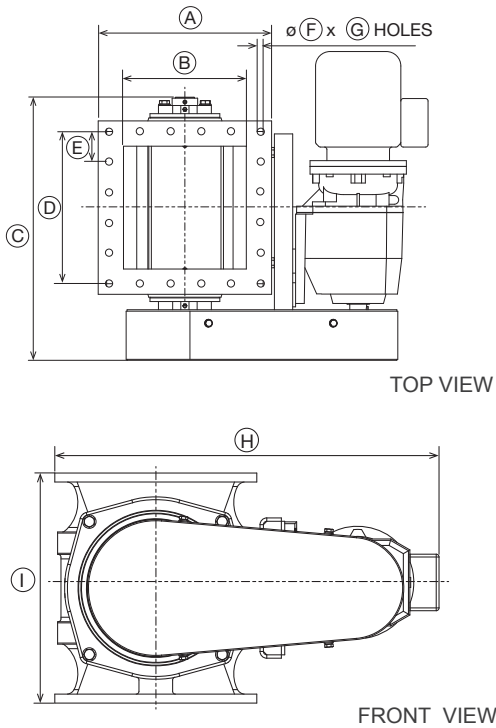

NAME	RH 150	RH 200	RH 250	RH 300	RH 350	RH 400	RH 500	RH 600	RH 750
A	□ 240	□ 300	□ 360	□ 430	□ 480	□ 530	□ 630	□ 760	□ 930
B	□ 150	□ 200	□ 250	□ 300	□ 350	□ 400	□ 500	□ 600	□ 750
C#	350	452	546	616	650	754	925	1060	1208
D	210	255	315	376	424	470	570	700	864
E	70	85	105	94	106	94	114	100	108
F	12	14	15	15	15	15	15	18	18
G	12	12	12	16	16	20	20	28	32
H*	451	600	685	740	772	905	1010	1140	1452
I	240	330	410	470	525	620	760	900	1120
NET WEIGHT	68	102	164	214	340	400	608	1143	1600
GROSS WEIGHT	88	125	186	245	370	432	636	1210	1690

ALL DIMENSIONS IN MM, WEIGHT IN KGS.

* APPROXIMATE DIMENSION ONLY. VARIES WITH MOTOR SIZE AND GEARBOX VARIATION.

ROTORS & TIPS

RH

The standard RH Series rotor is closed, which has the least amount of potential wear. Open rotors are provided where required. Where very stringy material is used, which can jam the rotor, adjustable rubber tipped rotors may be used. The rubber tip is reversible so it can be turned over for a new surface.

Also available in Closed rotor fabricated, Open rotor fabricated, Reduced pocket open rotor fabricated types.

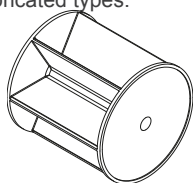

Closed Rotor

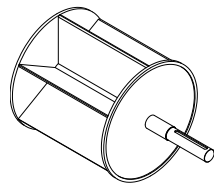

Closed Rotor Fabricated

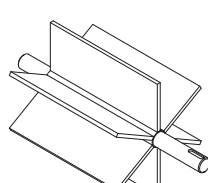

Open Rotor Fabricated

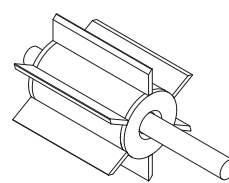

Reduced Pocket Open Rotor Fabricated

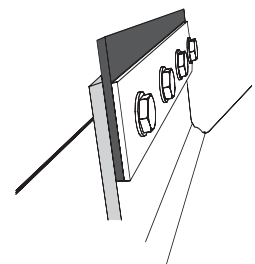

Typical Tipped Rotor Blade

SHAFT SEALING

RH

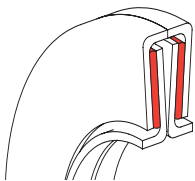

We are using labyrinth seal, which is a mechanical seal that fits around the axle or shaft to prevent the leakage of any particles. Generally, Labyrinth seal is composed of many threads or grooves that are tightly fit inside the casing, thus making difficult for the dust to pass through a long and difficult path.

Labyrinth seals on rotating shafts provide non contact sealing action by controlling the passage of particles through a variety of chambers by centrifugal motion, as well as by the formation of controlled material vortices.

'Double labyrinth Seals' are filled with flock pads, and greased on each side of the valve. These are standard with all RH Series valves.

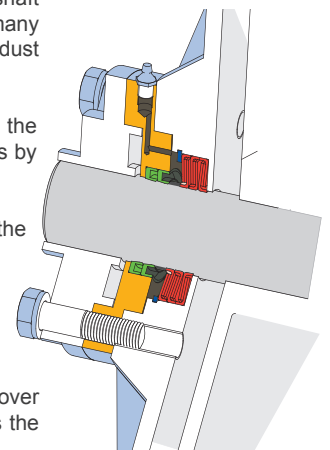

TYPICAL PURGE SEALING ARRANGEMENT

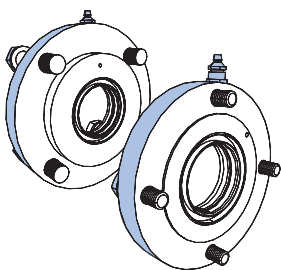

PURGE SEALING

Grease Purge - For extreme duty, valves can be fitted with a grease purge unit over the labyrinth seal. By creating a grease filled cavity between the seals, it prevents the escape of any dust particles or gases.

Air Purge - When grease cannot be used, air or other gases can be used to purge the seal so all dust particles or product gases are flushed back into the product stream.

MODEL SELECTION CHART

RH

Speed Vs Throughput

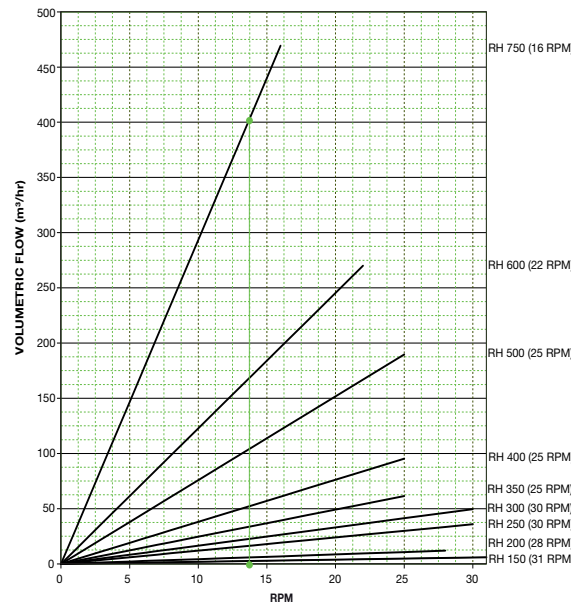

Capacity Chart

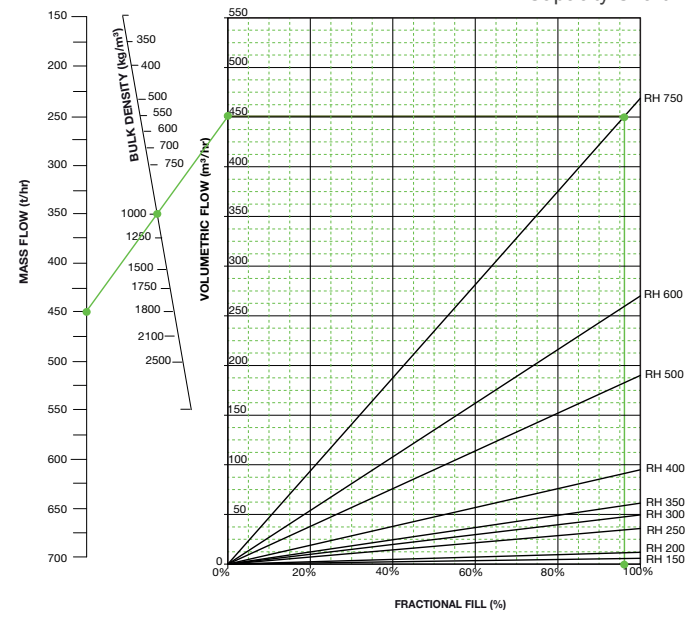

- 14 RPM DEFAULT FOR DIRECT (D) AND CHAIN (C) DRIVE
- RPM NOT REQUIRED FOR BARE SHAFT

NOTE: THIS CHART IS PREPARED FOR THE GUIDANCE PURPOSE ONLY, CONSIDERING 100% FILLING CAPACITY.

EXAMPLE: A MATERIAL WITH A BULK DENSITY OF 1000(KG/M³) AND REQUIRED CAPACITY OF 450(T/HR) CAN BE ACHIEVED BY RH 750 AT 96% FILLING CAPACITY. WITH 16 RPM.

NOTE: THIS CHART IS PREPARED FOR THE GUIDANCE PURPOSE ONLY, CONSIDERING 100% FILLING CAPACITY.

CONSTRUCTION / TECHNICAL SPECIFICATIONS

RH

BODY	: Cast Iron	BEARINGS	: Cartridge Type
ROTOR	: Cast Iron / MS	SHAFT	: CS1030
SIDE PLATES	: Cast Iron	OPENING SIZES	: 150 to 750 mm
GEARBOX	: Heliworm or Helibevel Gears (D) / Helical Gears (C)	TEMPERATURE	: Build to eminent temperature
SEALS	: Labyrinth Seals (sealing washer)	DIFFERENTIAL PRESSURE	: Can handle higher pressure
DRIVE TYPE	: Direct / Chain / Bare shaft	CAPACITY RANGE	: Upto 550 m³/hr Max.
ROTOR TYPE	: Closed rotor (N) / Closed rotor fabricated (M) / Open rotor fabricated (Q) / Reduced pocket open rotor fabricated (R)	PAINTING STANDARD	: Dark Grey Blue
ROTOR TIPS	: Flexible Tips (F) / Wear Tips (W)	SURFACE TREATMENT (ANVAL STANDARD)	: 50µm Grey Primer 50µm Paracryl IFC (B53 Dk. Grey Blue / Y14 Golden Yellow for guards)
SENSOR	: Proximity Sensor (P)	SURFACE TREATMENT (HIGH TEMPERATURE)	: 75µm ES600 Zinc Silicate Primer 40µm Heatkote Aluminium
SPECIAL SEALS	: Grease Purge (G) / Air Purge (A)		

NOTE: SPECIAL CONSTRUCTIONS ARE AVAILABLE FOR HIGHER DIFFERENTIAL PRESSURE AND TEMPERATURE.

