

RFS SERIES

ROTARY FLOATING SHOE VALVES

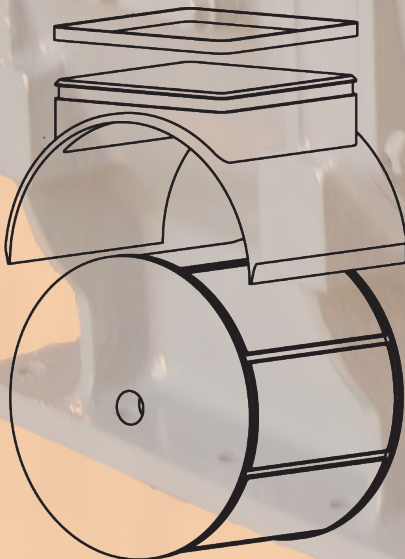
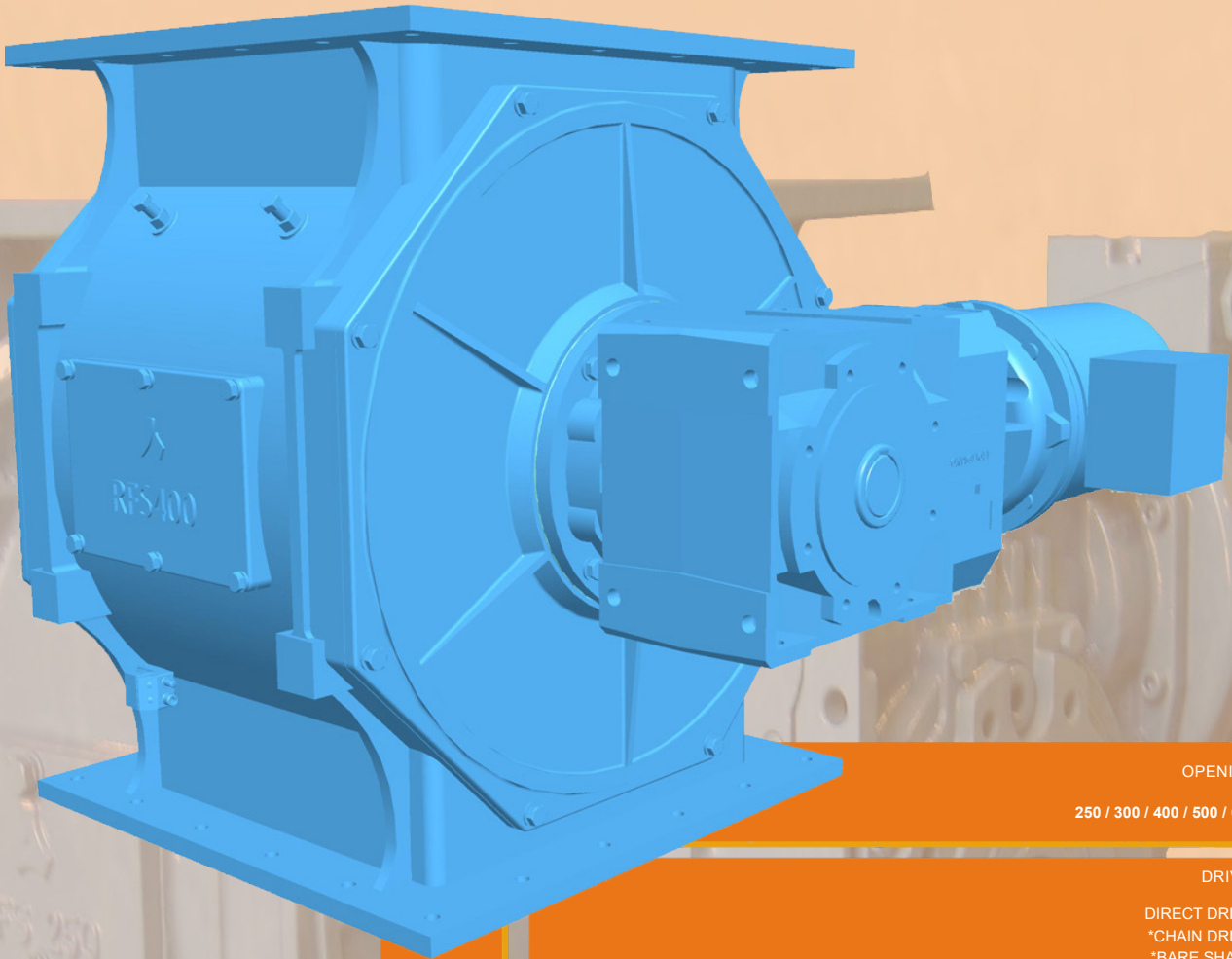

OPENING SIZE
250 / 300 / 400 / 500 / 600 / 750

DRIVE TYPE
DIRECT DRIVE : D
*CHAIN DRIVE : C
*BARE SHAFT : B

ROTOR SPEED

PURGE SEALING
GREASE PURGE : G
AIR PURGE # : A
For temperature > 300 °C

TEMPERATURE RANGE
200 - 300 °C : X
300 - 400 °C : Y
> 400 °C : Z

UNDERSPEED SENSORS
NONE : -
PROXIMITY SENSOR : P

RFS 600 D 14 - - -

BASIC DESIGNATION

EXTENDED DESIGNATION

*DEFAULT
#MANDATORY

DIRECT DRIVE (D) > DIMENSIONS

RFS

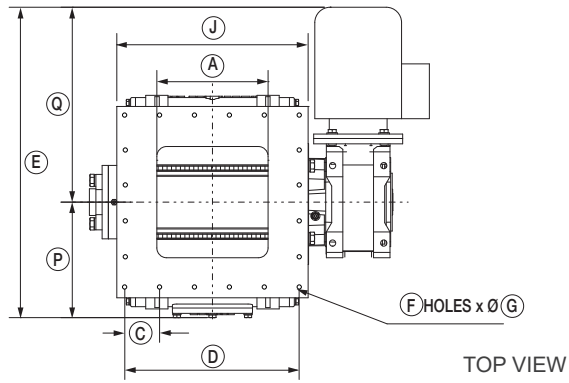

TOP VIEW

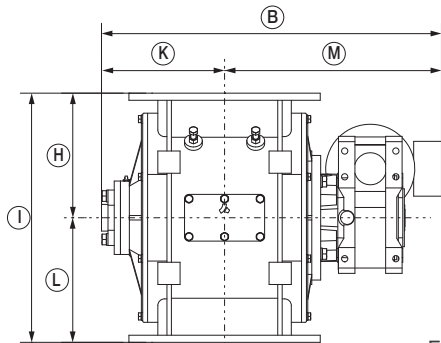

FRONT VIEW

NAME	RFS 250	RFS 300	RFS 400	RFS 500	RFS 600	RFS 750
A	□ 250	□ 300	□ 400	□ 500	□ 600	□ 750
B#	765	775	1000	1100	1275	1540
C	94	106	114	130	150	150
D	376	424	570	650	750	900
E#	698	859	1024	1104	1238	1423
F	16	16	20	20	20	24
G	15	15	14	18	22	22
H	280	300	400	470	565	650
I	560	600	800	940	1130	1300
J	□ 430	□ 480	□ 630	□ 700	□ 844	□ 1000
K	277	283	350	425	500	585
L	280	300	400	470	565	650
M	488	493	650	675	775	955
NET WEIGHT	268	331	643	1038	1546	2239
GROSS WEIGHT	290	361	673	1068	1575	2270

ALL DIMENSIONS IN MM AND WEIGHT IN KGS

APPROXIMATE DIMENSION ONLY. VARIES WITH MOTOR SIZE AND GEARBOX VARIATION.

CHAIN DRIVE (C)/ BARE SHAFT (B) > DIMENSIONS

RFS

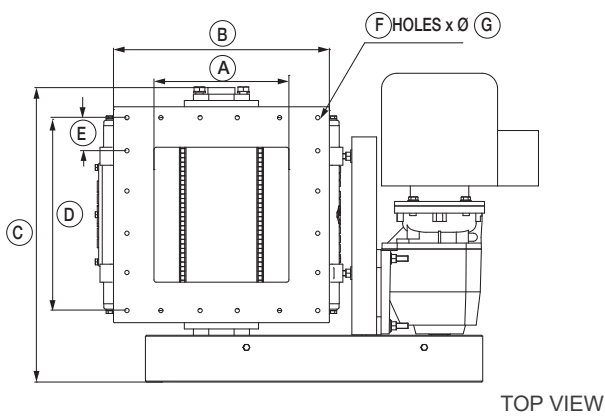

TOP VIEW

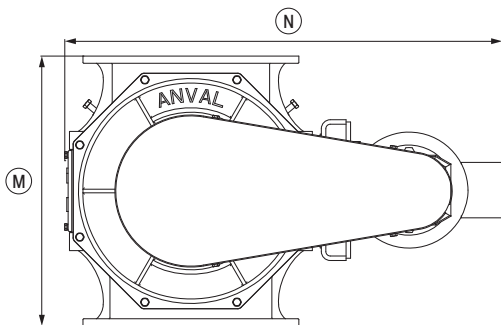
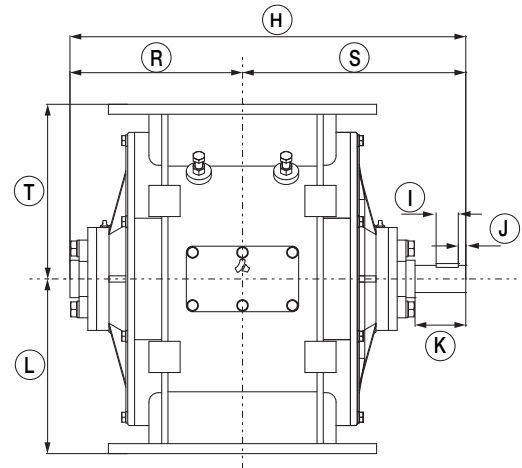

FRONT VIEW

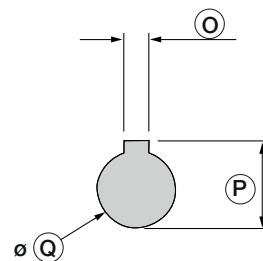

SHAFT SECTION

CHAIN DRIVE / BARE SHAFT > DIMENSIONS DATA

RFS

NAME	RFS 250	RFS 300	RFS 400	RFS 500	RFS 600	RFS 750
A	□ 250	□ 300	□ 400	□ 500	□ 600	□ 750
B	430 x 430	480 x 480	630 x 630	700 x 700	844 x 844	1000 x 1000
C#	625	655	902	955	1150	1395
D	376	424	570	650	750	900
E	94	106	114	130	150	150
F	16	16	20	20	20	24
G	15	15	14	18	22	22
H#	615	667	800	963	1117	1335
I	57	50	50	50	50	95
J	7	7	10	7	7	10
K	82	100	97	114	114	116
L	280	300	400	470	565	650
M	560	600	800	940	1130	1300
N#	875	936	1116	1295	1530	1872
O	14	14	18	18	20	22
P	53.5	53.5	64	69	79.5	85
Q	50	50	60	65	75	80
R	280	283	355	450	502	612
S	333	384	455	513	614	724
T	280	300	400	470	565	650
NET WEIGHT	293	354	675	1132	1735	2480
GROSS WEIGHT	318	388	703	1195	1815	2520

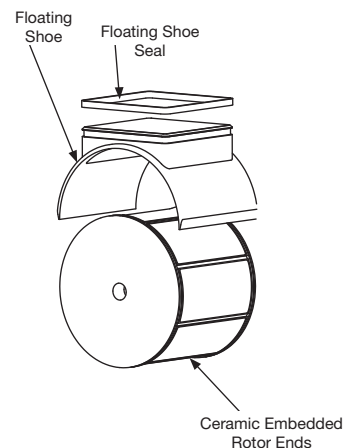

TYPICAL FLOATING SHOE ARRANGEMENT

APPROXIMATE DIMENSIONS ONLY. VARIES WITH MOTOR SIZE AND GEAR BOX VARIATION.

ALL DIMENSIONS IN MM AND WEIGHT IN KGS

PROXIMITY SENSORS

RFS

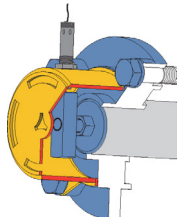

Underspeed sensors can be supplied and fitted to rotary valves. These are mounted on a specifically designed bracket that is bolted onto the bearing. The sensor fitted is 12mm in diameter with CD-PNP electrical connection and protection to IP67. The unit is suitable for temperatures from -25°C to +70°C.

SHAFT SEALING

RFS

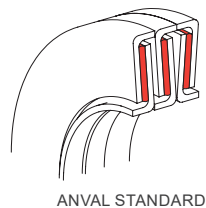

ANVAL STANDARD

We are using labyrinth seal, which is a mechanical seal that fits around the axle or shaft to prevent the leakage of any particles.

Generally, Labyrinth seal is composed of many threads or grooves that are tightly fit inside the casing, thus making difficult for the dust to pass through a long and difficult path.

Labyrinth seals on rotating shafts provide non contact sealing action by controlling the passage of particles through a variety of chambers by centrifugal motion, as well as by the formation of controlled material vortices.

'Triple labyrinth Seals' are filled with flock pads, and greased on each side of the valve. These are standard with all RFS Series valves.

Grease Purge - For extreme duty, valves can be fitted with a grease purge unit over the labyrinth seal. By creating a grease filled cavity between the seals, it prevents the escape of any dust particles or gases.

Air Purge - When grease cannot be used, air or other gases can be used to purge the seal so all dust particles or product gases are flushed back into the product stream.

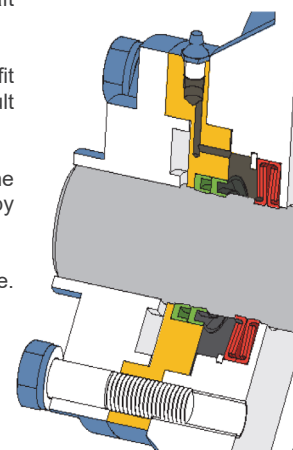

TYPICAL PURGE SEALING ARRANGEMENT

PURGE SEALING

HIGH TEMPERATURE

RFS

For high temperature applications, beyond 250°C, it is advisable that, the product need to be coated with heatkote aluminium. Also ceramic fibre sheets and flocs are provided to protect bearings and seals.

ROTARY FLOATING SHOE

The Anval RFS Series features a sacrificial, hardened SG iron adjustable shoe. The shoe, which sits on the rotor, has up to 10mm of wear and can be adjusted externally while in operation to maintain minimal clearance at all times.

Anval Rotary Floating Shoe Series Valve offers up to 4 times the life of a standard Rotary valve offering unparalleled value for high wearing products such as Alumina, iron ore, cement, coal, fly-ash and mineral sands.

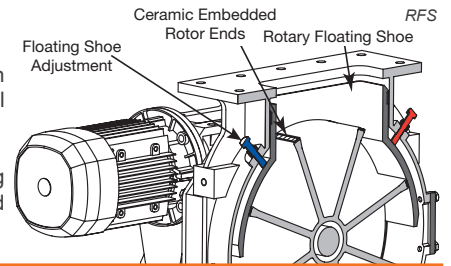

MODEL SELECTION DATA

Speed Vs Throughput

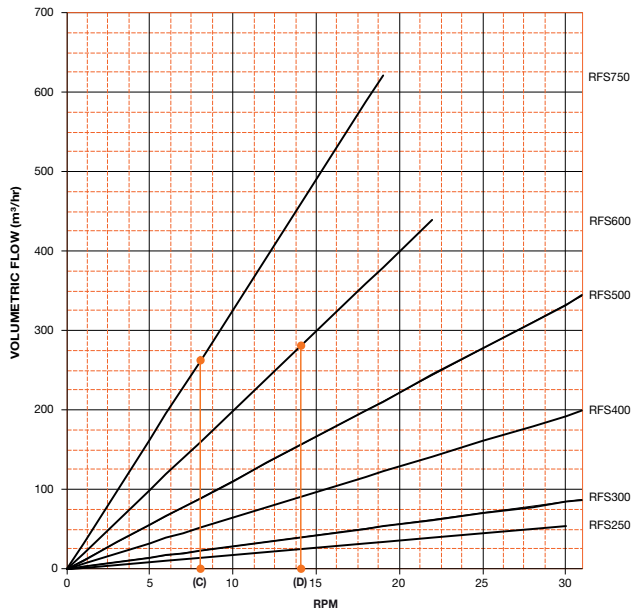

Capacity Chart

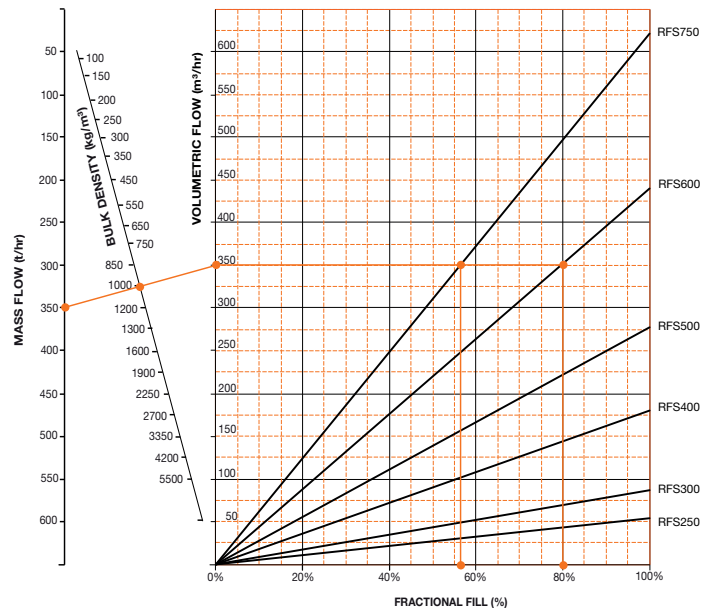

- 8 RPM DEFAULT FOR CHAIN DRIVE (C)
- 14 RPM DEFAULT FOR DIRECT DRIVE (D)

NOTE: THIS CHART IS PREPARED FOR THE GUIDANCE PURPOSE ONLY, CONSIDERING 100% FILLING CAPACITY.

EXAMPLE: A MATERIAL WITH A BULK DENSITY OF 1000 KG/M³ AND REQUIRED CAPACITY OF 350 T/HR CAN BE EACHIEVED BY RFS600 AT 80% FILLING CAPACITY WITH 22 RPM AND ALSO BY RFS750 AT 56% FILLING CAPACITY WITH 19 RPM.

NOTE: THIS CHART IS PREPARED FOR THE GUIDANCE PURPOSE ONLY, CONSIDERING MAX. RPM

CONSTRUCTION / TECHNICAL SPECIFICATIONS

BODY	: Cast Iron	BEARINGS	: Cartridge Type
ROTOR	: SG Iron	SHAFT	: CS1030
SIDE PLATES	: Cast Iron	OPENING SIZES	: 250, 300, 400, 500, 600, 750 mm
GEARBOX	: Heliworm or Helibevel Gears (D) / Helical Gears (C)	TEMPERATURE	: Build to eminent temperature
SEALS	: Labyrinth Seals	DIFFERENTIAL PRESSURE	: Can handle higher pressure
DRIVE TYPE	: Direct / Chain / Bare Shaft	CAPACITY RANGE	: Upto 621 m ³ /hr Max.
ROTOR TYPE	: Closed Rotor	PAINTING STANDARD	: Dark Grey Blue
ROTOR TIPS	: Ceramic Embedded	SURFACE TREATMENT (ANVAL STANDARD)	: 50µm Grey Primer 50µm Paracryl IFC (B53 Dk. Grey Blue / Y14 Golden Yellow for guards.)
SENSOR	: Proximity Sensor	SURFACE TREATMENT (HIGH TEMPERATURE : >200 °C)	: 75µm ES600 Zinc Silicate Primer 40µm Heatkote Aluminium
SPECIAL SEALS	: Grease Purge (G) / Gas Purge (A)		

NOTE: SPECIAL CONSTRUCTIONS ARE AVAILABLE FOR HIGHER DIFFERENTIAL PRESSURE AND TEMPERATURE.